

# GOLDEN EGGS

Visual Cook Book for: HP X86-64 Servers

- 1 - Front page
- 2 - HP ProLiant Family Map
- 3 - DL360 G6 Intel Xeon 2P 1U
- 4 - DL380 G6 Intel Xeon 2P 2U
- 5 - DL385 G6 AMD Opteron 2P 2U
  
- 6 - DL380 G5 Intel Xeon 2P 2U
- 7 - DL385 G5 AMD Opteron 2P 2U
- 8 - DL580 G5 Intel Xeon 4P 4U
- 9 - DL585 G5 AMD Opteron 4P 4U
- 10 - DL785 G5 AMD Opteron 8P 7U

Nehalem EP

Intel Xeon X5570 x86-64

2930MHz 2P-Quad

491332-421

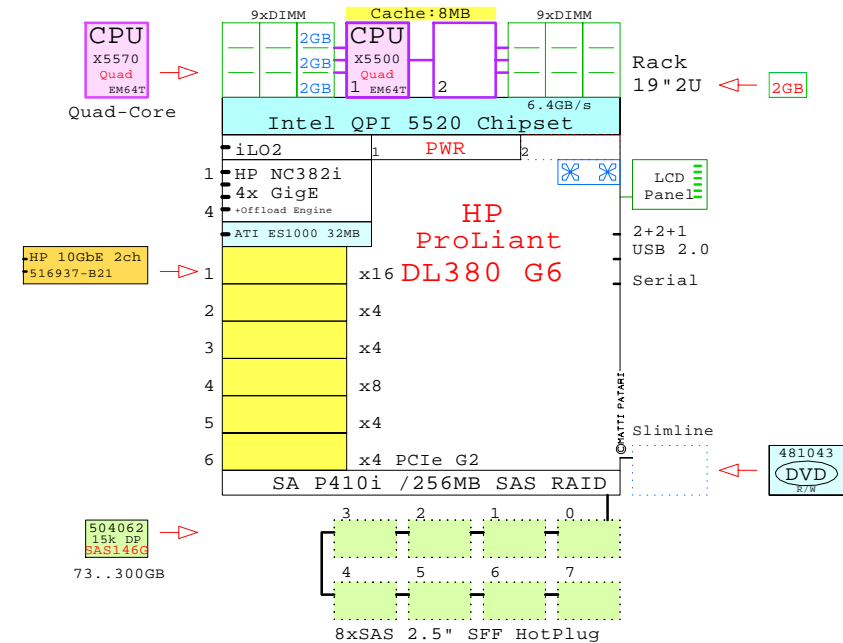

This document is a collection of HP x86-64 servers. It is prepared for End-customers, Partners and Sales personnel.  
A picture talks all languages.

Created by:  
 Matti.Patari@Kolumbus.Fi Helsinki

Tip for detail printing:  
 - Zoom in area of interest  
 - Print, Print Current View

Golden Eggs Home:  
<http://www.goldeneggs.fi>

GE-HP-X86-11-Mar-2010.pdf

© 2010 Matti Patari, All rights reserved.

GOLDEN EGGS Visuals™ Helsinki	11-Mar-2010	GE-HP-X86A
	Matti.Patari@Kolumbus.Fi	

HP x86 Servers 2P 4P 8P Intel AMD  
 GOLDEN EGGS Visuals, Helsinki

10-Gigabit  
Gigabit E  
Gigabit E  
iLO2 Remote Manager

### Opteron 8P

### Xeon 4P

### Opteron 4P

### Xeon 2P

### Opteron 2P

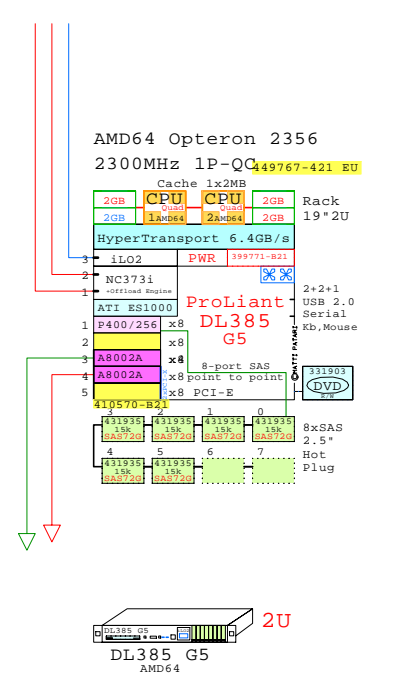
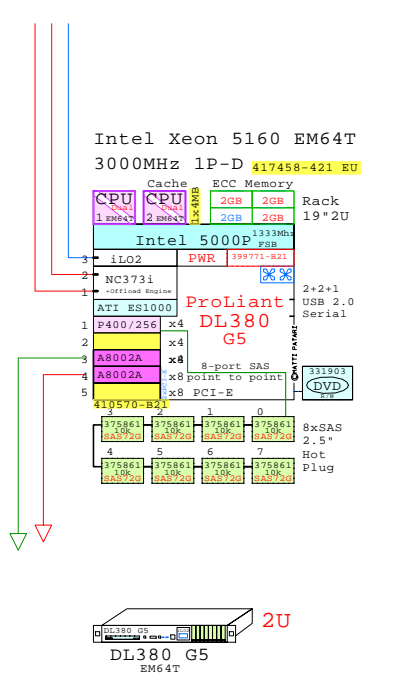
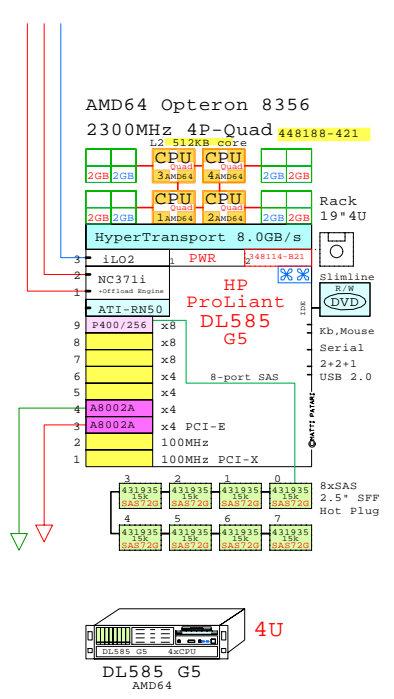
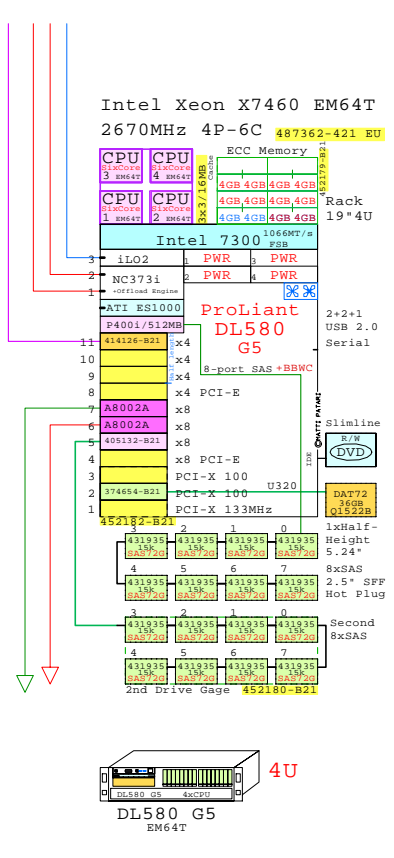
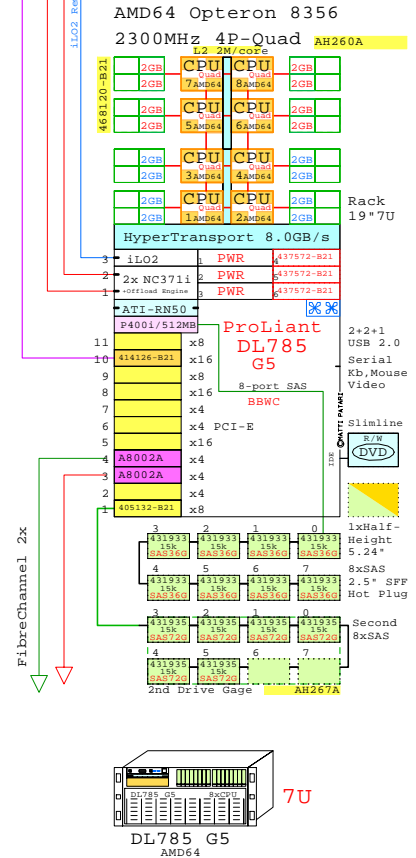

Tip for detail printing:  
 - Zoom in area of interest  
 - Print, Print Current View

© 2009 Matti Patari, All rights reserved.

GOLDEN EGGS Visuals™ Helsinki	09-Mar-2009	GE-HP-X86-FAMILY
Matti.Patari@Kolumbus.fi		

HP x86 Servers 8P,4P,2P Intel,AMD  
 GOLDEN EGGS Visuals, Helsinki  
File: rev 05-Feb-08

HP DL360-G6  
Xeon 5500

Internal Options:

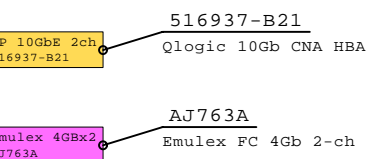
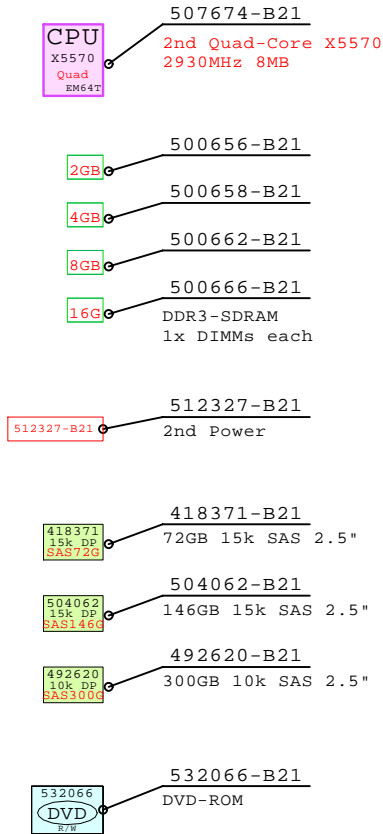

++ Plus many more std PCIe I/O modules...

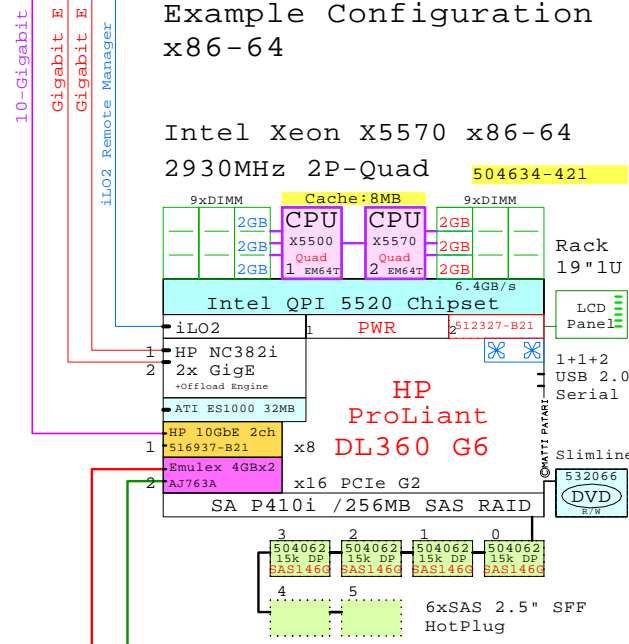

2x 4Gb Fibre Channel to external storage

Parts list for the 2P Quad-Core HP DL360-G6 system above

Part Number	Qty	Description
504634-421	1	HP DL360-G6 2P I QC X5570-8MB 6GB 1U
500656-B21	3	HP 2GB 2Rx8 PC3-10600R-9 kit 1x2GB
504062-B21	4	HP 146GB 3G 15k 2.5" SAS DualPort HDD
507674-B21	1	Xeon QC X5570-8MB 2.93GHz for DL360G6
512327-B21	1	DL380 G6 second power WW
516937-B21	1	HP 10GbE PCI-e G2 DualPort NIC
532066-B21	1	HP CD-RW/DVD-ROM Option kit DL360G6
AJ763A	1	HP Emulex FC 4Gb 2-ch HBA

Nehalem EP  
2930MHz Quad-Core

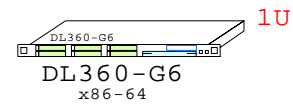
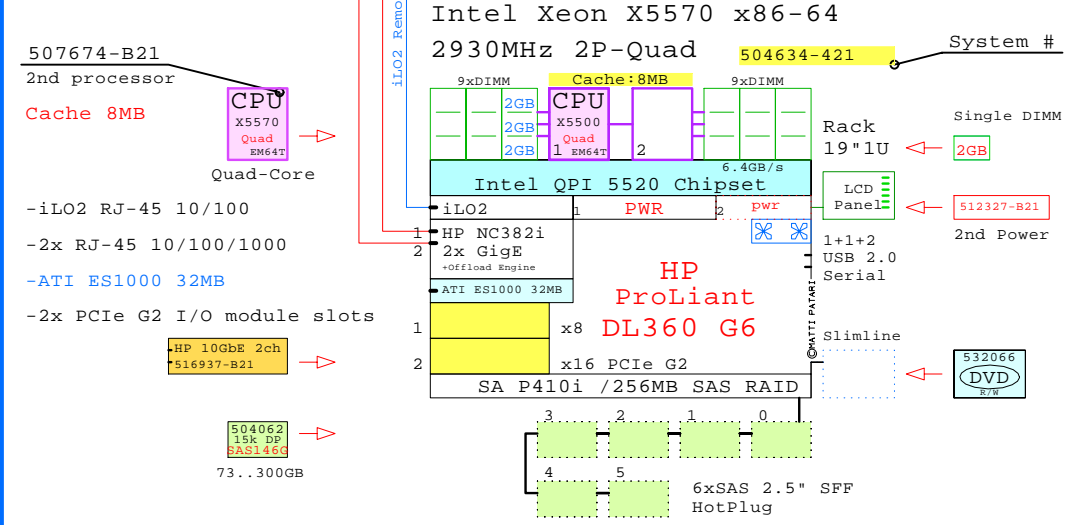

MS Windows Server 2003 and 2008  
LINUX: Red Hat, SuSE  
VMware Virtualization Software

Tip for detail printing:  
- Zoom in area of interest  
- Print, Print Current View

© 2010 Matti Patari, All rights reserved.

GOLDEN EGGS Visuals™ Helsinki	11-Mar-2010	GE-HP-DL360G6-A
		Matti.Patari@Kolumbus.Fi

HP DL360-G6 Intel 5500 2P/1U

HP ProLiant DL360-G6 X5570 2930Mz  
GOLDEN EGGS Visuals, Helsinki

HP DL380-G6  
Xeon 5500

Internal Options:

- 500094-B21  
CPU X5570 Quad EM64T  
2nd Quad-Core X5570  
2930MHz 8MB
- 500656-B21  
2GB
- 500658-B21  
4GB
- 500662-B21  
8GB
- 500666-B21  
16GB  
DDR3-SDRAM  
1x DIMMs each
- 512327-B21  
2nd Power
- 418371-B21  
418371  
15k DP  
SAS72G  
72GB 15k SAS 2.5"
- 504062-B21  
504062  
15k DP  
SAS146G  
146GB 15k SAS 2.5"
- 492620-B21  
492620  
10k DP  
SAS300G  
300GB 10k SAS 2.5"
- 481043-B21  
481043  
DVD  
DVD-ROM
- 516937-B21  
HP 10GbE 2ch  
516937-B21  
Qlogic 10Gb CNA HBA
- AJ763A  
Emulex FC 4Gb 2-ch

10-Gigabit  
Gigabit E  
Gigabit E  
iLO2 Remote Manager

Example Configuration  
x86-64

Intel Xeon X5570 x86-64  
2930MHz 2P-Quad 491332-421

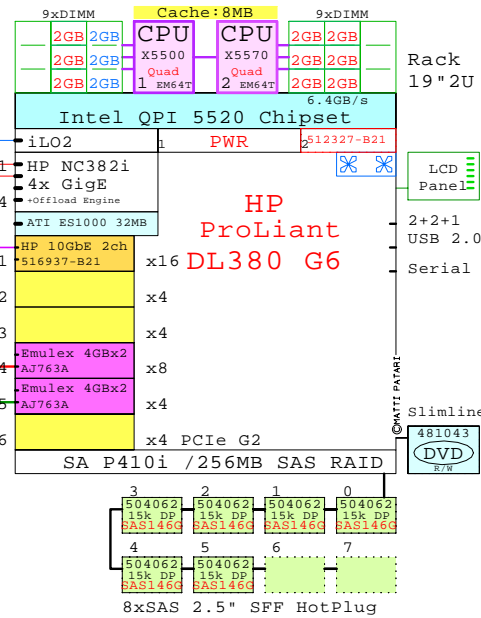

2x 4Gb Fibre Channel to external storage

Parts list for the 2P Quad-Core HP DL380-G6 system above

Part Number	Qty	Description
491332-421	1	HP DL380-G6 2P I QC X5570-8MB 6GB 2U
481043-B21	1	HP CD-RW/DVD-ROM Option kit, slimline
500094-B21	1	Xeon QC X5570-8MB 2.93GHz for DL380G6
500656-B21	9	HP 2GB 2Rx8 PC3-10600R-9 kit 1x2GB
504062-B21	6	HP 146GB 3G 15k 2.5" SAS DualPort HDD
512327-B21	1	DL380 G6 second power supply WW
516937-B21	1	HP 10GbE PCI-e G2 DualPort NIC
AJ763A	2	HP Emulex FC 4Gb 2-ch HBA

Nehalem EP  
2930MHz Quad-Core

Intel Xeon X5570 x86-64  
2930MHz 2P-Quad 491332-421

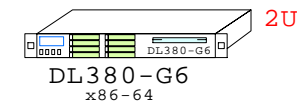
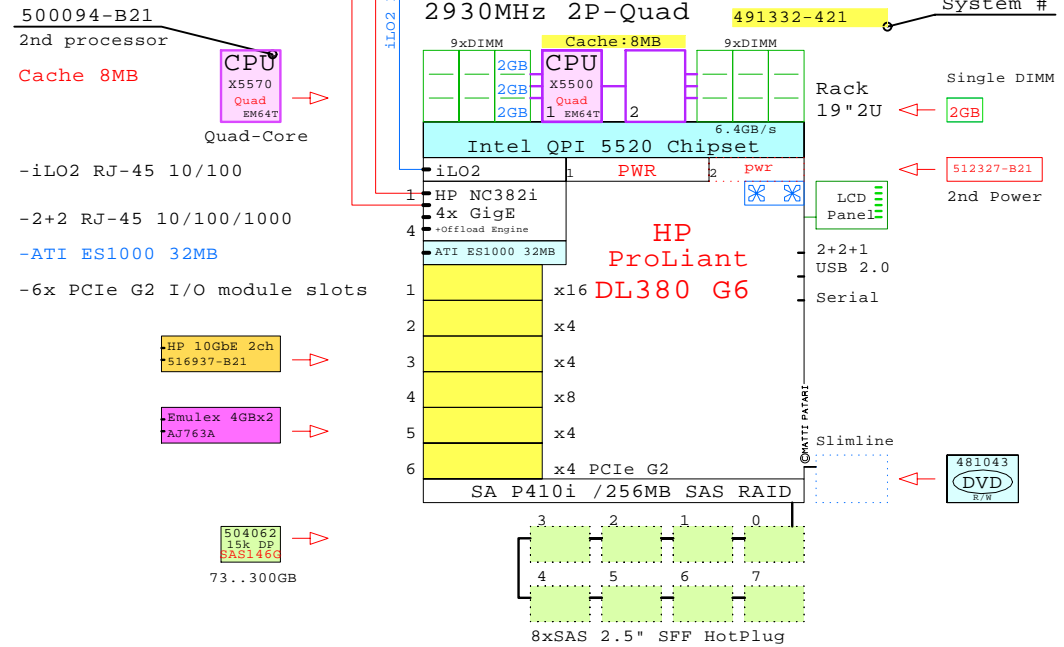

MS Windows Server 2003 and 2008  
LINUX: Red Hat, SuSE  
VMware Virtualization Software

Tip for detail printing:  
- Zoom in area of interest  
- Print, Print Current View

© 2010 Matti Patari, All rights reserved.

GOLDEN EGGS Visuals™ Helsinki	11-Mar-2010	GE-HP-DL380G6-A
		Matti.Patari@Kolumbus.Fi

HP ProLiant DL380-G6 X5570 2930Mz  
GOLDEN EGGS Visuals, Helsinki

HP DL380-G6 Intel 5500 2P/2U

HP DL385-G6  
AMD Opteron

Internal Options:

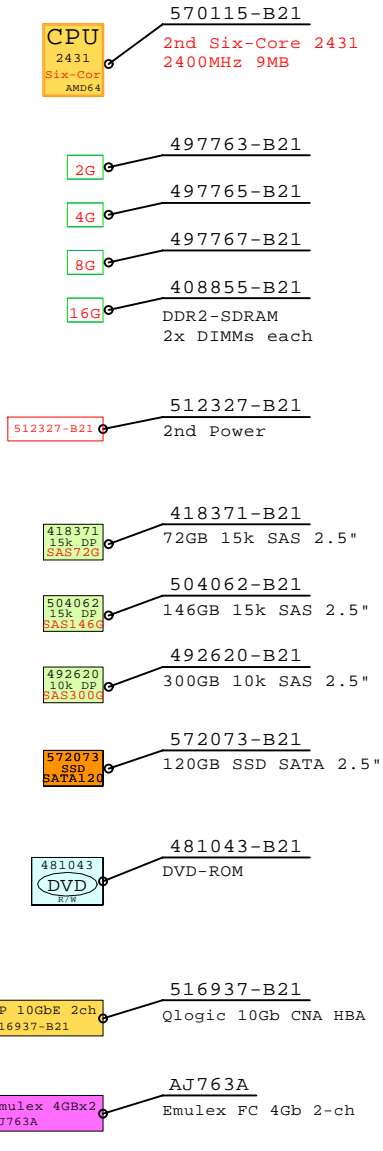

Example Configuration  
x86-64

AMD Opteron 2431 x86-64  
2400MHz 2P Six-C 570103-421 EU

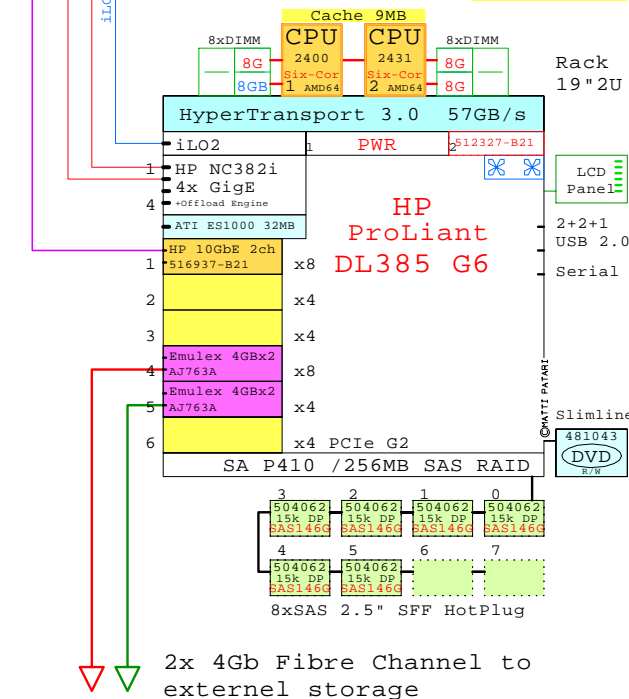

Parts list for the 2P Six-Core HP DL385-G6 system above

Part Number	Qty	Description
570103-421	1	DL385 G6 1P 6C 2431 2.4GH 8GB AMD64 SAS
481043-B21	1	HP CD-RW/DVD-ROM Option kit, slimline
497767-B21	3	Mem 8GB REG PC2-6400 DDR2 2x4GB Kit
504062-B21	6	HP 146GB 3G 15k 2.5" SAS DualPort HDD
512327-B21	1	DL380 G6 second power supply WW
516937-B21	1	HP 10GbE PCI-e G2 DualPort NIC
570115-B21	1	DL385-G6 2.4GHz 6C AMD64 2431 CPU kit
AJ763A	2	HP Emulex FC 4Gb 2-ch PCIe HBA

++ Plus many more std PCIe I/O modules...

HP DL385-G6 AMD Six-Core 2P/2U

Istanbul  
2400MHz Six-Core

AMD Opteron 2431 x86-64  
2400MHz 2P Six-C 570103-421 EU System #

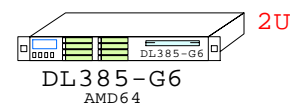
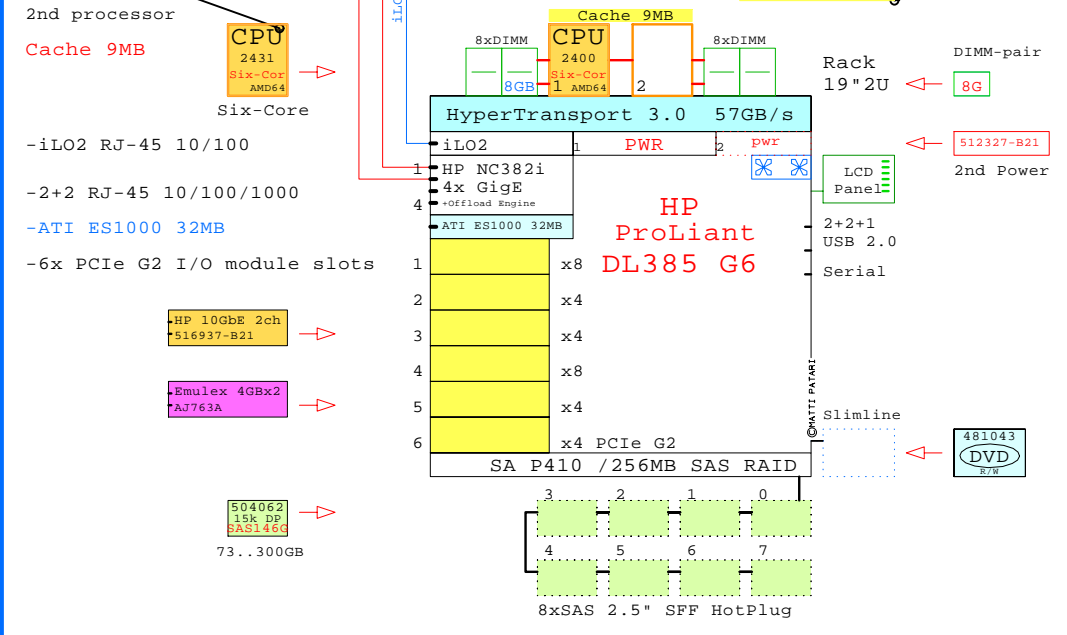

MS Windows Server 2003 and 2008  
LINUX: Red Hat, SuSE  
VMware Virtualization Software

Tip for detail printing:  
- Zoom in area of interest  
- Print, Print Current View

© 2010 Matti Patari, All rights reserved.

GOLDEN EGGS Visuals™ Helsinki	11-Mar-2010	GE-HP-DL385G6-A
		Matti.Patari@Kolumbus.Fi

HP DL385-G6 AMD Opteron Six-Core  
GOLDEN EGGS Visuals, Helsinki

Internal Options:

- 418324-B21  
CPU Dual EM64T  
2nd Dual Core  
3000MHz 1x4MB
- 397409-B21  
1GB
- 397411-B21  
2GB
- 397413-B21  
4GB
- 397415-B21  
8GB  
DDR2-SDRAM  
2x DIMMs each
- 399771-B21  
G5 2nd power
- 375859-B21  
36GB 10k SAS  
SAS36G
- 375861-B21  
72GB 10k SAS  
SAS72G
- 431958-B21  
146GB 10k SAS  
SAS146G
- 331903-B21  
DVD-ROM

- 367047-B21  
NC320T 1000T  
PCI-E Gigabit
- 414126-B21  
NC510F One Port  
PCI-E 10-Gigabit
- A8003A  
A8003A  
FibChan PCI-E HBA  
2ch 4Gb FC2242SR

- 410570-B21  
PCI-E/PCI-X  
Riser cage for  
PXI-X HBAs

- 273915-B21  
Smart Array PCI-X  
6402/128 2-Ch

- 257894-006  
Myrinet XP-Fibre  
M3F-PCIXD-2

Example Configuration

Intel Xeon 5160 EM64T  
3000MHz 1P-D 417458-421 EU

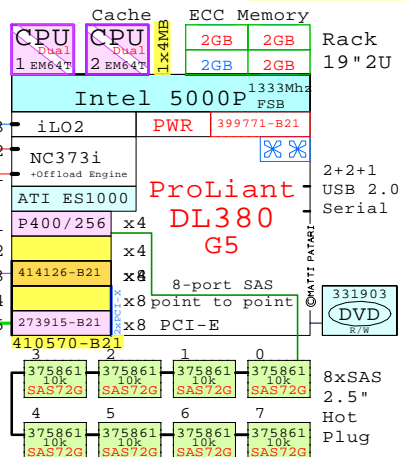

External Two Channel SCSI

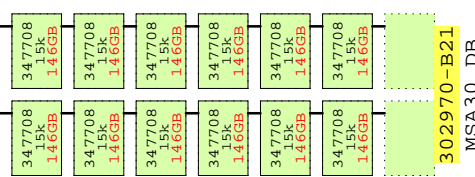

Parts list for the example system above

Part Number	Qty	Description
417458-421	1	DL380 G5 1P DC 5160-1x4MB 2GB SAS 2U EM6
331903-B21	1	CD-RW/DVD-ROM Option kit, slimline
375861-B21	8	HP 72GB SAS 10000r hot-plug disk 2.5"
397411-B21	3	BL460c Memory 2GB 2x1GB
399771-B21	1	DL380 G5 second power supply WW
410570-B21	1	Riser cage PCI-E/PCI-X DL380 G5
273915-B21	1	Smart Array 6402/128 Ultra320 2-chan
414126-B21	1	HP NC510F PCI-E 10-Gigabit Server Adapte
418324-B21	1	Xeon DC 5160-1x4MB 3000MHz for DL380G5
302970-B21	1	MSA30 Dual Buss Ultra320 7+7 1"
347708-B21	12	146.8GB 15000r U320 disk 1"

3000MHz Dual/Quad Core

Intel Xeon 5160 EM64T  
3000MHz 1P-D 417458-421 EU  
Memory Max:  
4x8GB=32GB

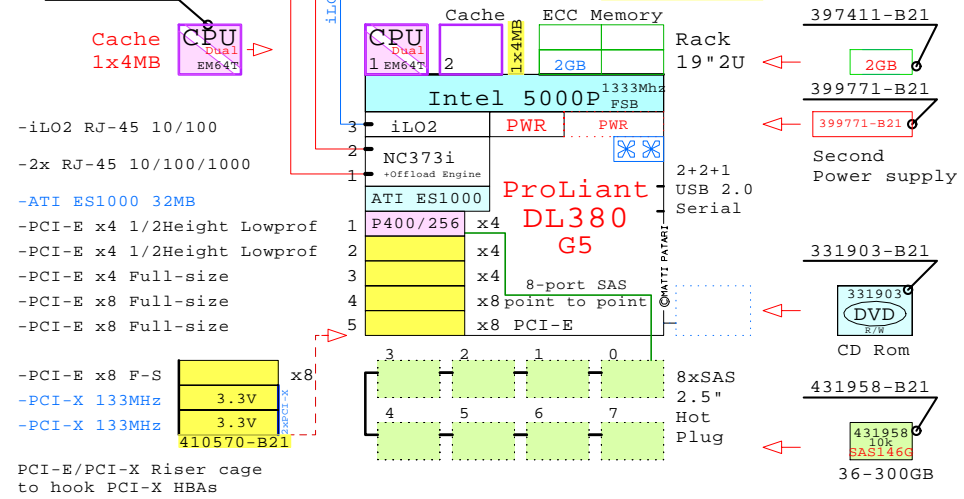

More DL380 G5 systems are serviced on page 2.

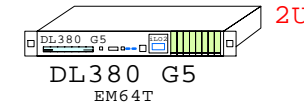
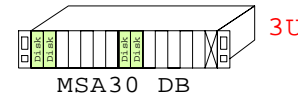

MS Windows Server 2000  
MS Windows Server 2003  
Novell NetWare  
LINUX: Red Hat, SuSE  
SCO UnixWare, OpenServer  
VMware Virtualization Software  
Solaris 10 32/64-bit

Tip for detail printing:  
- Zoom in area of interest  
- Print, Print Current View

Your comments are appreciated.  
Matti.Patari@Kolumbus.Fi GE-Painter.

© 2006 Matti Patari, All rights reserved.

GOLDEN EGGS Visuals™ Helsinki	29-Dec-2006	GE-HP-DL380G5-A
	Matti.Patari@Kolumbus.Fi	



Internal Options:

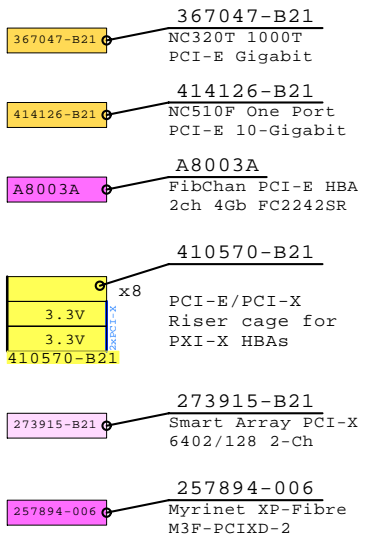
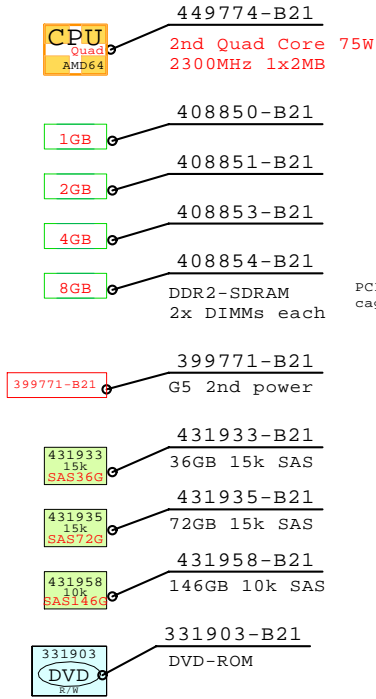

Example Configuration

AMD64 Opteron 2356  
2300MHz 1P-QC 449767-421 EU

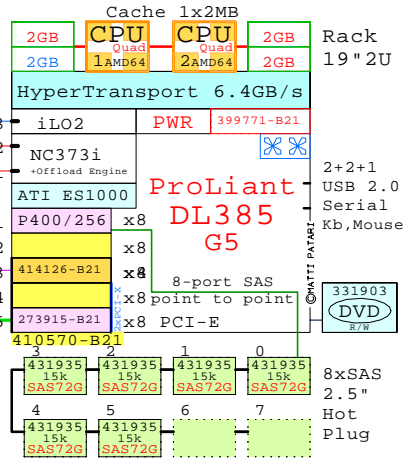

External Two Channel SCSI

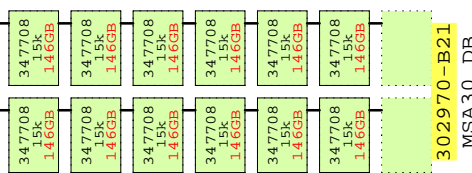

Parts list for the example system above

	Part Number	Qty	Description
1	449767-421	1	DL385 G5 1P QC 2356 2.3GH 2GB AMD64 SAS
1.1	331903-B21	1	CD-RW/DVD-ROM Option kit, slimline
1.2	399771-B21	1	DL380 G5 second power supply WW
1.3	408851-B21	3	2GB PC2-5300 DDR2 kit 2x1GB DL385G2
1.4	410570-B21	1	Riser cage PCI-E/PCI-X DL380 G5
1.4.1	273915-B21	1	Smart Array 6402/128 Ultra320 2-chan
1.4.2	414126-B21	1	HP NC510F PCI-E 10-Gigabit Server Adapte
1.5	431935-B21	6	HP 72GB SAS 15000r hot-plug disk 2.5"
1.6	449774-B21	1	Opteron QC 2356-2MB 2300MHz for DL385G5
2	302970-B21	1	MSA30 Dual Buss Ultra320 7+7 1"
2.1	347708-B21	12	146.8GB 15000r U320 disk 1"

Barcelona

2300MHz Quad Core

AMD64 Opteron 2356  
2300MHz 1P-QC 449767-421 EU

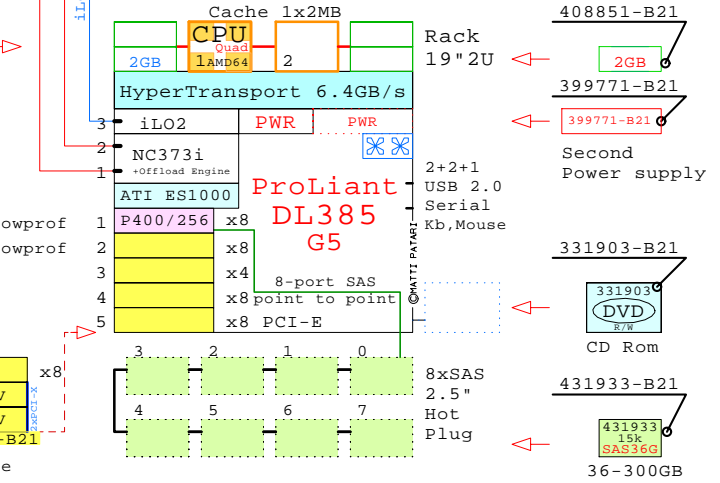
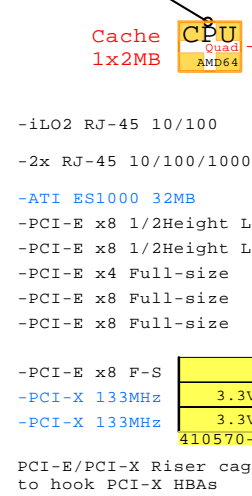

More DL385 G5 systems are serviced on page 2.

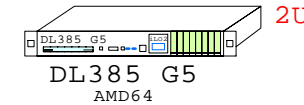
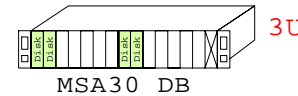

MS Windows Server 2003 and 2008  
LINUX: Red Hat, SuSE  
VMware Virtualization Software  
Sun Solaris

Tip for detail printing:  
- Zoom in area of interest  
- Print, Print Current View

© 2008 Matti Patari, All rights reserved.

GOLDEN EGGS Visuals™ Helsinki	12-Jun-2008	GE-HP-DL385G5-A
	Matti.Patari@Kolumbus.Fi	

HP ProLiant DL580 G5

Internal Options:

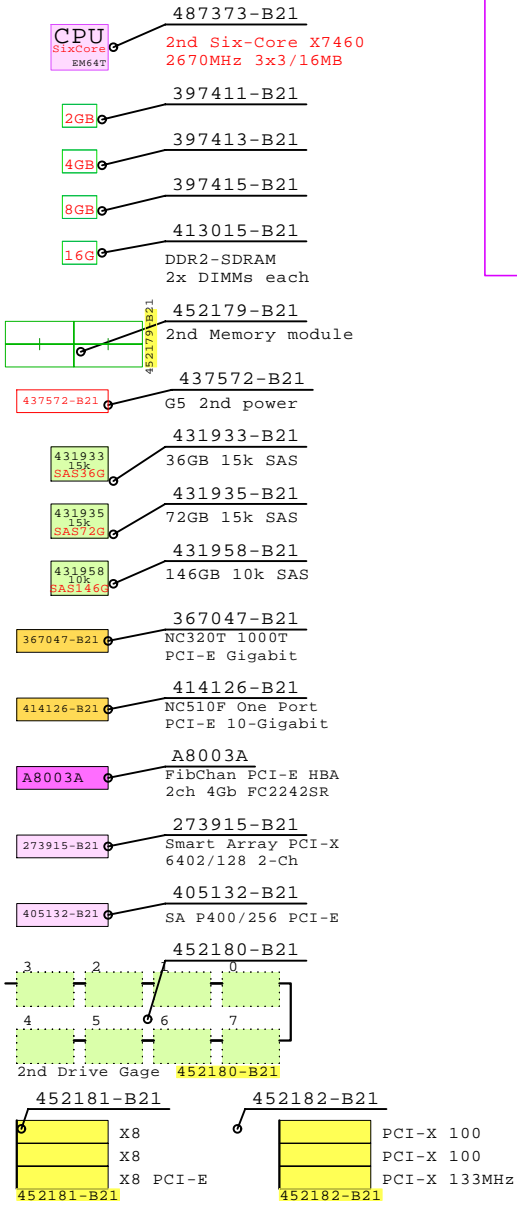

453744-B21 DL580-G5 Tower kit

Example Configuration  
x86-64 6-Core

Intel Xeon X7460 EM64T  
2670MHz 4P-6C 487362-421 EU

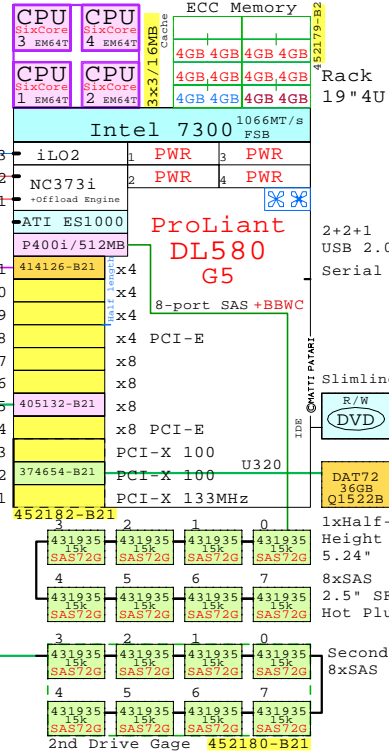

Parts list for the 4P Six-Core X7460 system above

Part Number	Qty	Description
1	487362-421	1 DL580 G5 4P 6C X7460-16MB 16GB Rack 4U
1.1	397413-B21	6 HP Blade BL460c Memory 4GB 2x2GB
1.2	405132-B21	1 HP Smart Array P400/256 PCI-E HBA
1.3	414126-B21	1 HP NC510F PCI-E 10-Gigabit Server Adapter
1.4	431935-B21	8 HP 72GB SAS 15000r hot-plug disk 2.5"
1.5	452179-B21	1 Memory Board kit DL580 G5
1.5.1	397413-B21	4 HP Blade BL460c Memory 4GB 2x2GB
1.6	452180-B21	1 2nd Drive Gage 8xSFF SAS DL580 G5
1.6.1	431935-B21	8 HP 72GB SAS 15000r hot-plug disk 2.5"
1.7	452182-B21	1 PCI-X 3-slot option DL580 G5
1.7.1	374654-B21	1 HP Single Ch U320 SCSI HBA
1.8	Q1522B	1 HP DAT 72 36GB internal drive

2670MHz Six-Core x86-64

Intel Xeon X7460 EM64T  
2670MHz 4P-6C 487362-421 EU

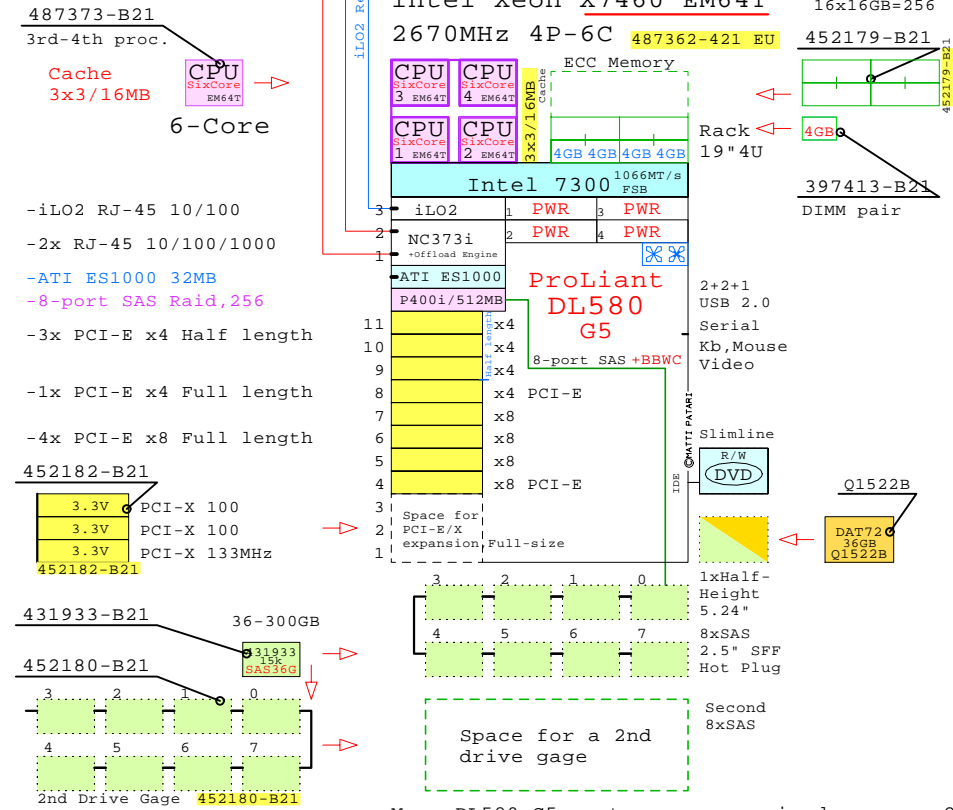

More DL580 G5 systems are serviced on page 2.

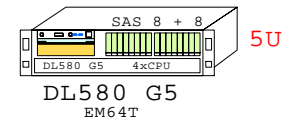

MS Windows Server 2003  
Novell NetWare  
LINUX: Red Hat, SuSE  
VMware Virtualization Software

Tip for detail printing:  
- Zoom in area of interest  
- Print, Print Current View

© 2008 Matti Patari, All rights reserved.

GOLDEN EGGS Visuals™ Helsinki	28-Nov-2008	GE-HP-DL580G5-A Matti.Patari@Kolumbus.Fi
-------------------------------	-------------	---

HP ProLiant DL580 G5 X7460 2670MH  
GOLDEN EGGS Visuals, Helsinki



# HP ProLiant DL585 G5

## Internal Options:

- CPU** **CPU** 448192-B21  
2x AMD 8354  
Cache  
512KB/core
- 408851-B21  
2GB
- 408853-B21  
4GB
- 408854-B21  
8GB  
DDR2-SDRAM  
2x DIMMs each
- 348114-B21  
G5 2nd power
- 390164-B21  
Slimline  
RX
- 431933-B21  
36GB 15k SAS
- 431935-B21  
72GB 15k SAS
- 431958-B21  
146GB 10k SAS
- 367047-B21  
NC320T 1000T  
PCI-E Gigabit
- 414126-B21  
NC510F One Port  
PCI-E 10-Gigabit
- A8003A  
FibChan PCI-E HBA  
2ch 4Gb FC2242SR
- 273915-B21  
Smart Array PCI-X  
6402/128 2-Ch
- 405132-B21  
SA P400/256 PCI-E

## Example Configuration

### AMD64 Opteron 8356

2300MHz 4P-Quad 448188-421

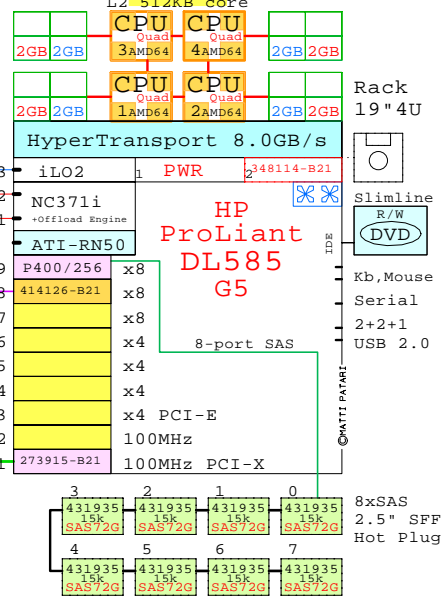

### External Two Channel SCSI

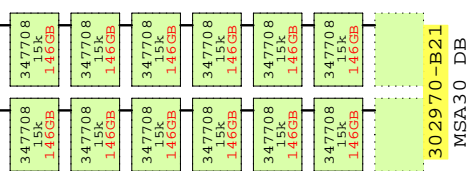

### Parts list for the 4P Quad-Core Opteron 8356 2.3GHz system

Part Number	Qty	Description
448188-421	1	DL585 G5 4P QC AMD8356 4x512KB 8GB 2.3GH
273915-B21	1	Smart Array 6402/128 Ultra320 2-chan
348114-B21	1	DL580 G3 second power supply
390164-B21	1	DL580 G3 Slimline Floppy Drive
408851-B21	4	2GB PC2-5300 DDR2 kit 2x1GB DL385G2
414126-B21	1	HP NC510F PCI-E 10-Gigabit Server Adapte
431935-B21	8	HP 72GB SAS 15000r hot-plug disk 2.5"
302970-B21	1	MSA30 Dual Buss Ultra320 7+7 1"
347708-B21	12	146.8GB 15000r U320 disk 1"

## 2200MHz Quad-Core

### AMD64 Opteron 8354

2200MHz 2P-Quad 448187-421

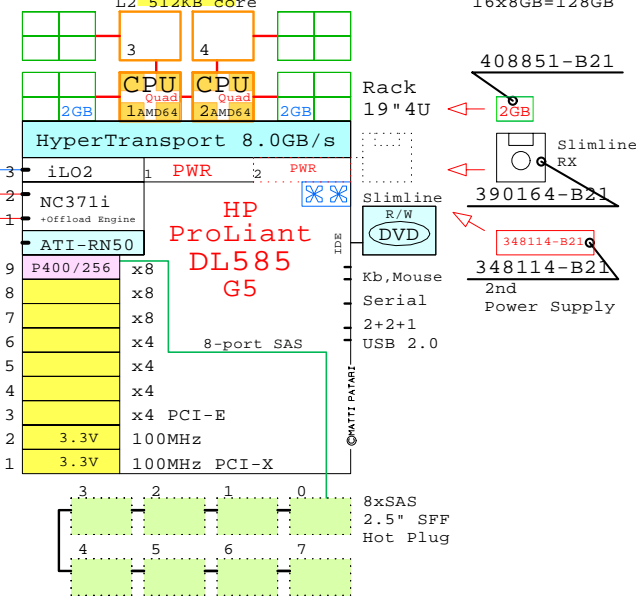

More DL585 G2 systems are serviced on page 2.

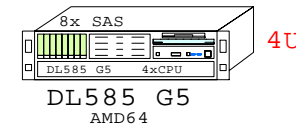
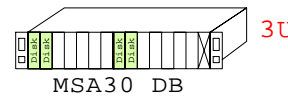

MS Windows Server 2003 and 2008  
 LINUX: Red Hat, SuSE  
 VMware Virtualization Software  
 Sun Solaris

Tip for detail printing:  
 - Zoom in area of interest  
 - Print, Print Current View

© 2008 Matti Patari, All rights reserved.

GOLDEN EGGS Visuals™ Helsinki	08-Apr-2008	GE-HP-DL585G5-A
		Matti.Patari@Kolumbus.Fi

# HP ProLiant DL785 G5

## Internal Options:

### Optional P5--P8 CPUs

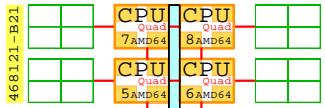

4x Opteron 8354, 2200MHz  
Cache 2MB/core,  
No memory

- 408851-B21 (2GB)
- 408853-B21 (4GB)
- 408854-B21 (8GB)
- 437572-B21 (G5 2nd power)
- 431933-B21 (36GB 15k SAS)
- 431935-B21 (72GB 15k SAS)
- 431958-B21 (146GB 10k SAS)
- 367047-B21 (NC320T 1000T PCI-E Gigabit)
- 414126-B21 (NC510F One Port PCI-E 10-Gigabit)
- A8003A (FibChan PCI-E HBA 2ch 4Gb FC2242SR)
- 405132-B21 (SA P400/256 PCI-E)

# Example Configuration

## AMD64 Opteron 8356

### 2300MHz 4P-Quad AH260A

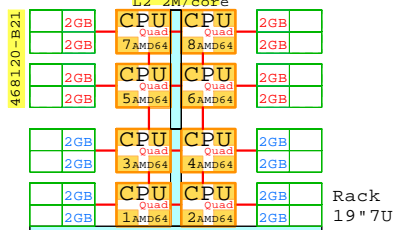

HyperTransport 8.0GB/s  
3 iLO2  
2x NC371i  
1 PWR  
1 PWR  
1 PWR

ATI-RN50  
P400i/512MB  
11 x8  
10 x16  
9 414129-B21 x8  
8 x16  
7 x4  
6 x4 PCI-E  
5 x16  
4 x4  
3 x4  
2 x4  
1 405132-B21 x8

ProLiant DL785 G5  
8-port SAS  
2+2+1 USB 2.0  
Serial Kb, Mouse Video  
Slimline DVD

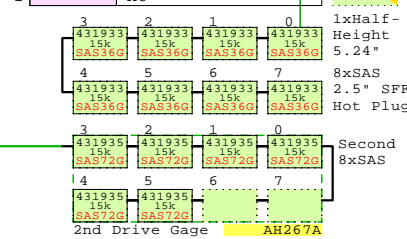

1xHalf-Height 5.24"  
8xSAS  
2.5" SFF Hot Plug  
Second 8xSAS

## Parts list for the 8P Quad-Core Opteron 8356 system above

Part Number	Qty	Description
1 AH260A	1	DL785 G5 4P QC AMD8356 4x2MB 16GB 2.3GHz
1.1 405132-B21	1	HP Smart Array P400/256 PCI-E HBA
1.2 414129-B21	1	HP NC510C PCI-E 10-Gigabit Server Adapter
1.3 431933-B21	8	HP 36GB SAS 15000r hot-plug disk 2.5"
1.4 437572-B21	3	DL580 G5 second power supply WW
1.5 468120-B21	1	5-8P CPU AMD64 QC 8356 2.30GHz DL785 G5
1.5.1 408851-B21	8	2GB PC2-5300 DDR2 kit 2x1GB DL385G2
1.6 AH267A	1	2nd Drive Gage 8xSFF SAS DL785 G5
1.6.1 431935-B21	6	HP 72GB SAS 15000r hot-plug disk 2.5"

# 2200MHz 8xQuad-Core

## AMD64 Opteron 8354

### 2200MHz 4P-Quad AH261A

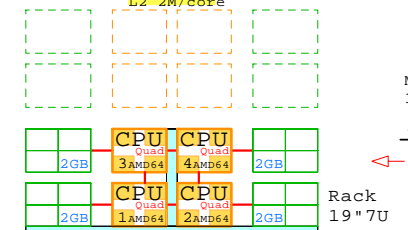

HyperTransport 8.0GB/s  
3 iLO2  
2x NC371i  
1 PWR  
1 PWR  
1 PWR

ATI-RN50  
P400i/256MB  
11 x8  
10 x16  
9 x8  
8 x16  
7 x4  
6 x4 PCI-E  
5 x16  
4 x4  
3 x4  
2 x4  
1 x8

ProLiant DL785 G5  
8-port SAS  
2+2+1 USB 2.0  
Serial Kb, Mouse Video  
Slimline DVD

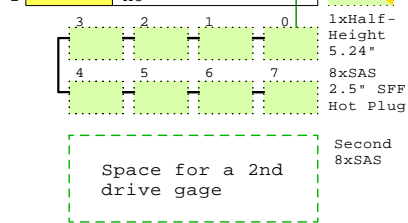

1xHalf-Height 5.24"  
8xSAS  
2.5" SFF Hot Plug  
Second 8xSAS

### Optional P5--P8 CPUs

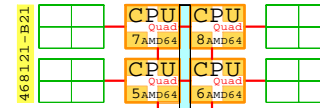

468121-B21  
4x Opteron 8354,  
Cache 2MB/core,  
No memory

- iLO2 RJ-45 10/100
- 2x RJ-45 10/100/1000
- ATI ES1000 32MB
- 8-port SAS Raid, 256
- 5x PCI-E x4 Full-size
- 3x PCI-E x8 Full-size
- 3x PCI-E x16 Full-size

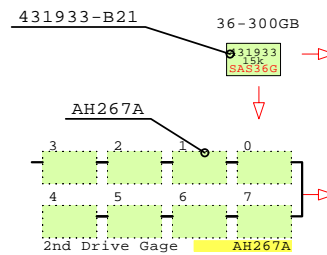

Memory Max: 32x8GB=256GB  
408851-B21 (2GB)  
DIMM pair 2x 1GB  
437572-B21 (Optional Power supply)

More DL785 G5 systems are serviced on page 2

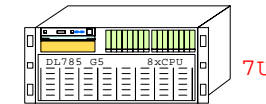

DL785 G5 AMD64

MS Windows Server 2003 - 2008  
LINUX: Red Hat, SuSE  
VMware Virtualization Software

Tip for detail printing:  
- Zoom in area of interest  
- Print, Print Current View

© 2008 Matti Patari, All rights reserved.

GOLDEN EGGS Visuals™ Helsinki	14-May-2008	GE-HP-DL785G5-A
		Matti.Patari@Kolumbus.Fi